

NOTES: UNLESS OTHERWISE SPECIFIED

- BATTERY CONFORMS TO THE DESIGN REQUIREMENTS OF 14 CFR PART 23.1353, 25.1353(c), 27.1353, 29.1353(c).
- INSPECT PER FAR 21.303(h) QUALITY SYSTEM.
- SEE DRAWING NO. CB-00127 AND PROCEDURE P-1000 FOR ASSEMBLY AND TEST INSTRUCTION. PROCEDURES AND ASSEMBLY DRAWINGS ARE FOR INTERNAL USE ONLY.

REVISIONS			
REV	DESCRIPTION	DATE	APPROVED
A	43 AH WAS 47 AH	2/10/05	JBT

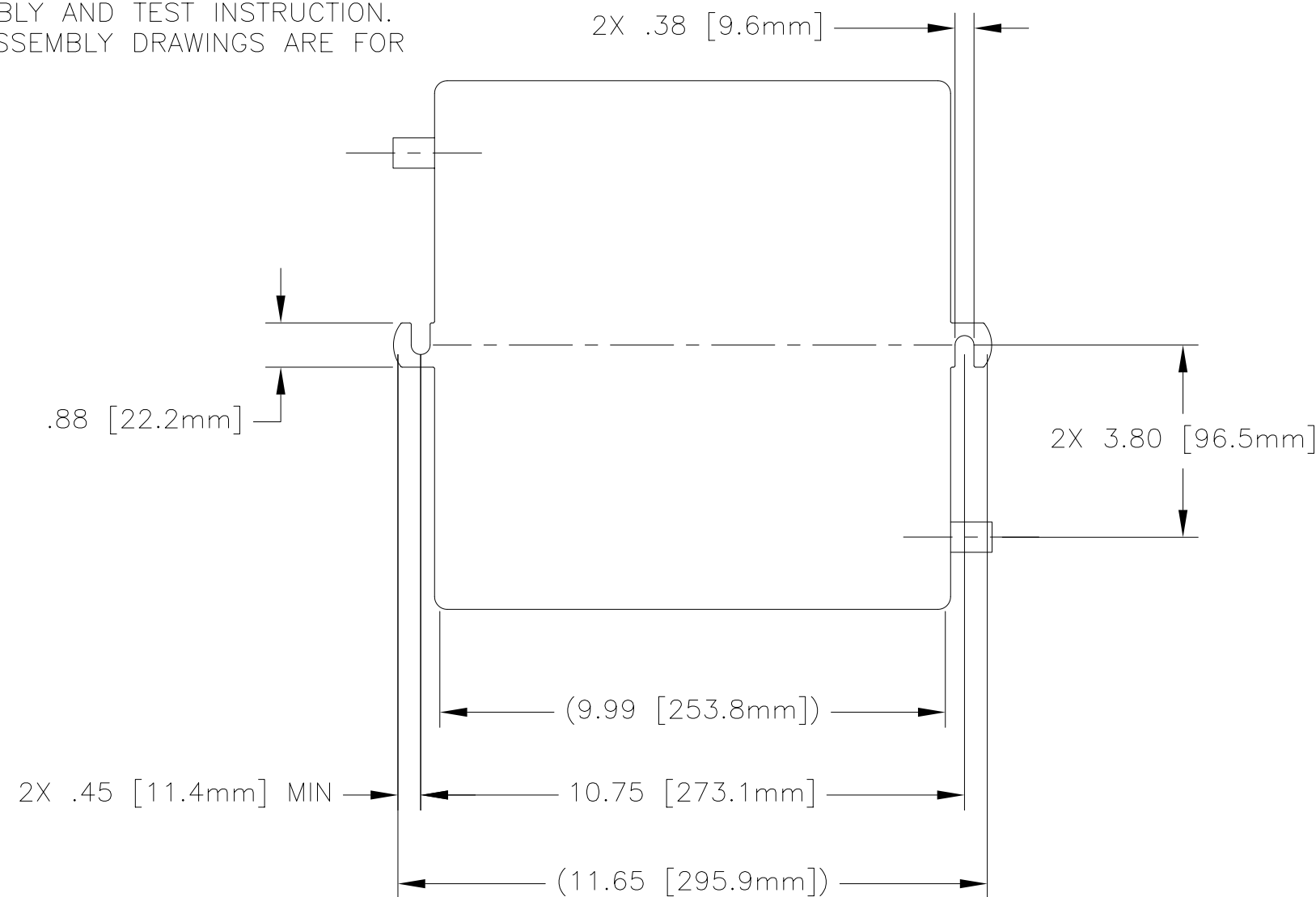

PART NUMBER	CB24-380E
MAXIMUM WEIGHT	80 LBS [36.3 KG]
RATED CAPACITY, C <sub>1</sub>	43 AH
30 MIN AH	79
60 SEC COLD CRANKING AH	505
5 HRS AH	57
RESERVE CAPACITY	121

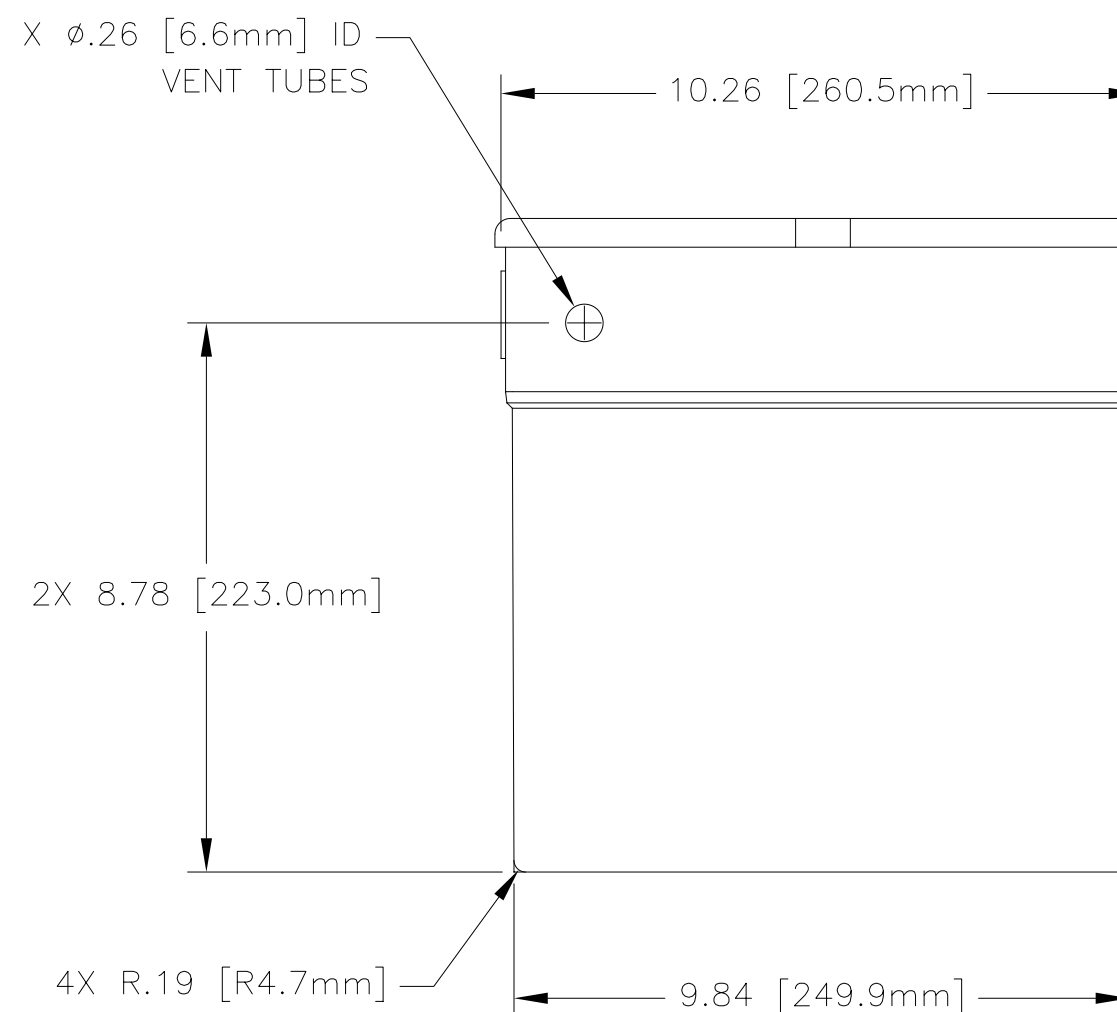
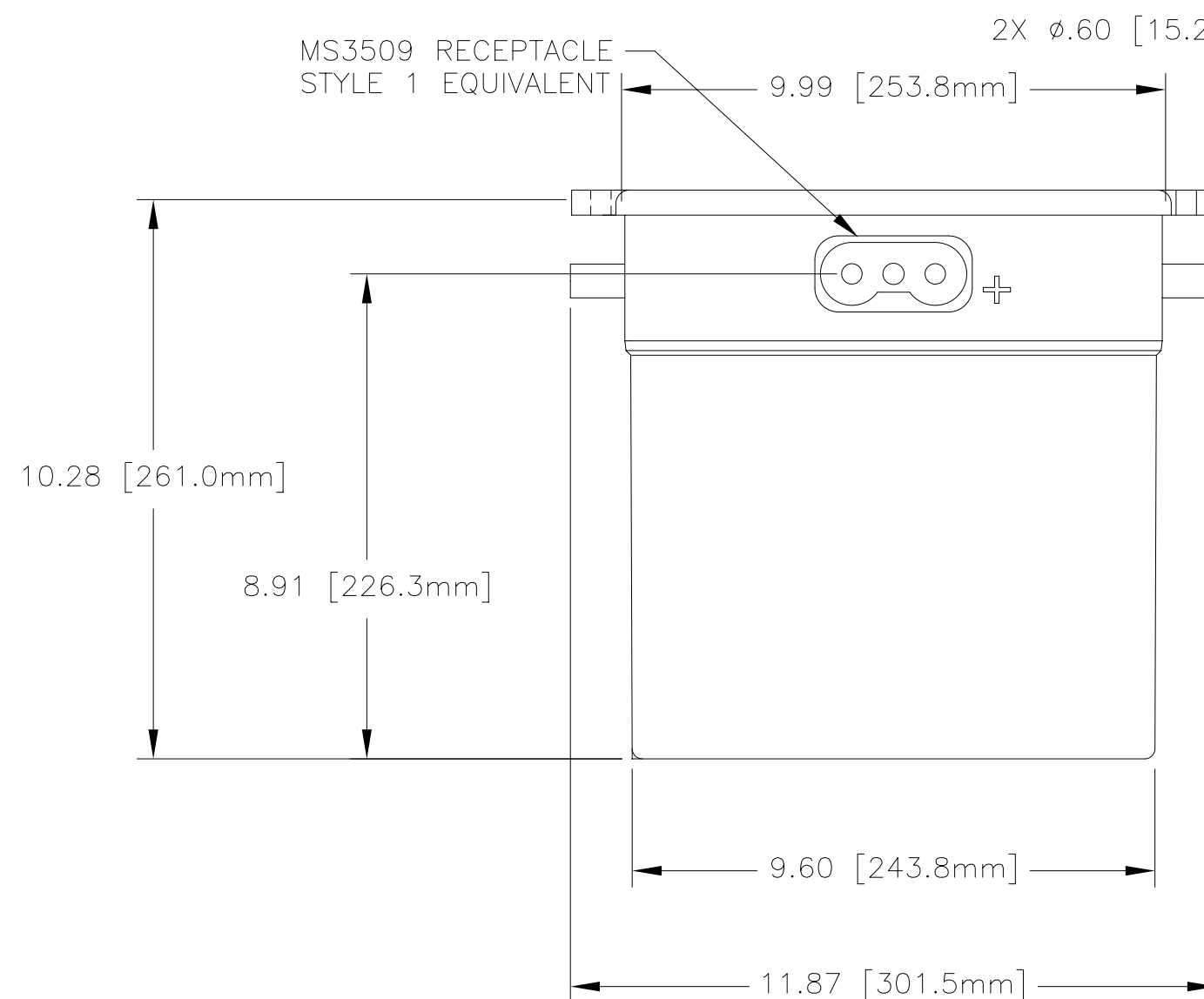

ENVELOPE DRAWING

QTY REQD	CAGE CODE	PART OR IDENTIFYING NO.	NOMENCLATURE OR DESCRIPTION	MATERIAL SPECIFICATION	ITEM NO.
PARTS LIST					
UNLESS OTHERWISE SPECIFIED DIMENSIONS ARE IN INCHES TOLERANCES ARE:			CONTRACT NO.		
FRACTIONS	DECIMALS	ANGLES	CONCORDE BATTERY CORPORATION		
.XX ± .03	.XXX ± .010		2009 SAN BERNARDINO RD, W. COVINA, CA 91790		
TREATMENT	APPROVALS	DATE	TITLE		
FINISH	DRAWN S. VALDEZ	1/12/00	BATTERY, LEAD ACID, 24 VOLT		
SIMILAR TO	CHECKED SV	1/12/00	SIZE	CAGE CODE	DWG NO.
ACT WT	APPROVED JBT	1/13/00	C	63017	CB24-380E
CALC WT	ISSUED DC	2/10/05	SCALE	1/3	REV A
				SHEET	1 OF 1

ENGINEERING COPY 10FEB05